

iglidur® Z – The High Temperature Material



- For high temperature applications
- High thermal resistance
- For extreme loads
- For high surface speeds
- Resistant to edge loads



iglidur® Z | The High Temperature Material

iglidur® Z is a high temperature bearing material, which is suited for applications with very high specific loads. iglidur® Z is suited for both medium and high speeds due to its high thermal resistance.

iglidur® Z

3 styles
> 50 dimensions
Ø 4-62 mm



Phone +49 - 22 03 - 96 49-145
Fax +49 - 22 03 - 96 49-334

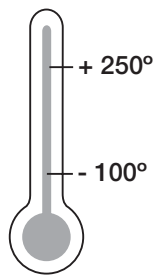

igus® GmbH
51147 Cologne

Price index



The High Temperature Material



When to use iglidur® Z plain bearings:

- For continuous temperatures up to 250°C or 310°C short term
- For high radial loads and high temperature
- For high surface speeds
- For edge loading in connection with high surface pressures



When not to use iglidur® Z plain bearings:

- For low loads and temperatures
▶ iglidur® P (chapter 17)
- When a cost-effective general purpose bearing is sought
▶ iglidur® G (chapter 2)
- When electrically conductive bearings are needed
▶ iglidur® F (chapter 11),
H (chapter 12),
H370 (chapter 15)

Internet www.igus.de
E-mail info@igus.de

Material Table

General Properties	Unit	iglidur® Z	Testing Method
Density	g/cm ³	1,40	
Colour		Brown	
Max. moisture absorption at 23°C / 50% r.F.	% weight	0,3	DIN 53495
Max. moisture absorption	% weight	1,1	
Coefficient of sliding friction, dynamic against steel	μ	0,06 - 0,14	
p x v value, max. (dry)	MPa x m/s	0,84	

Mechanical Properties

Modulus of elasticity	MPa	2.400	DIN 53457
Tensile strength at 20°C	MPa	95	DIN 53452
Compressive strength	MPa	65	
Max. recommended surface pressure (20°C)	MPa	150	
Shore D hardness		81	DIN 53505

Physical and Thermal Properties

Max. long term application temperature	°C	250	
Max. short term application temperature	°C	310	
Minimum application temperature	°C	-100	
Thermal conductivity	W/m x K	0,62	ASTM C 177
Coefficient of thermal expansion	K ⁻¹ x 10 ⁻⁵	4	DIN 53752

Electrical Properties

Specific volume resistance	Ωcm	> 10 ¹¹	DIN IEC 93
Surface resistance	Ω	> 10 ¹¹	DIN 53482

Table 22.1: Material Data

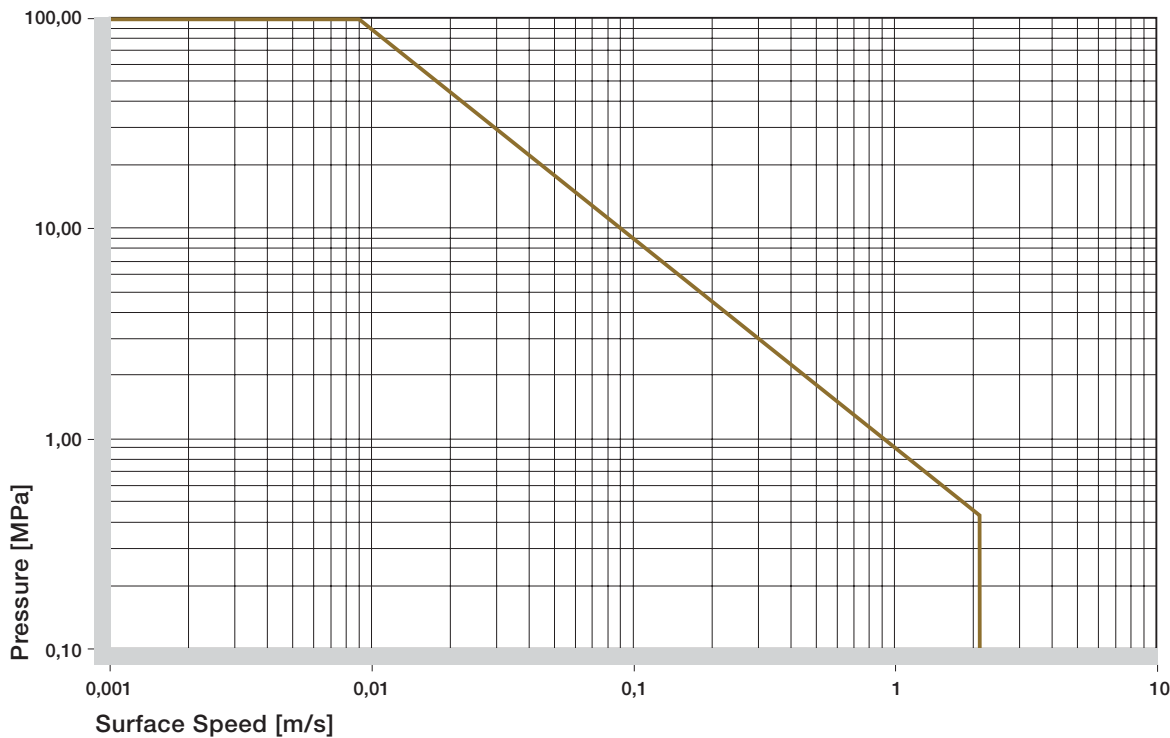

Graph 22.1: Permissible p x v values for iglidur® Z running dry against a steel shaft, at 20°C



iglidur® Z

Phone +49 - 22 03 - 96 49-145
Fax +49 - 22 03 - 96 49-334

igus® GmbH
51147 Cologne

Internet www.igus.de
E-mail info@igus.de

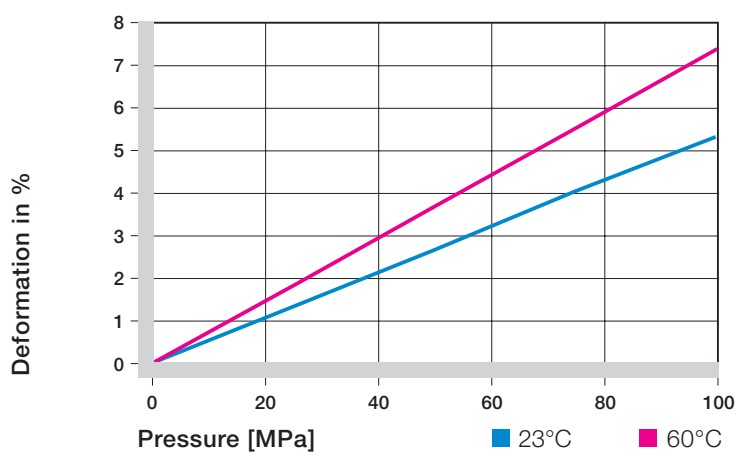

Graph 22.2: Deformation under pressure and temperature

m/s	Rotating	Oscillating	Linear
Continuous	1,5	1,1	5
Short term	3,5	2,5	6

Table 22.2: Maximum surface speed

iglidur® Z	Application Temperature
Minimum	- 100 °C
Max. long term	+ 250 °C
Max. short term	+ 310 °C

Table 22.3: Temperature limits for iglidur® Z

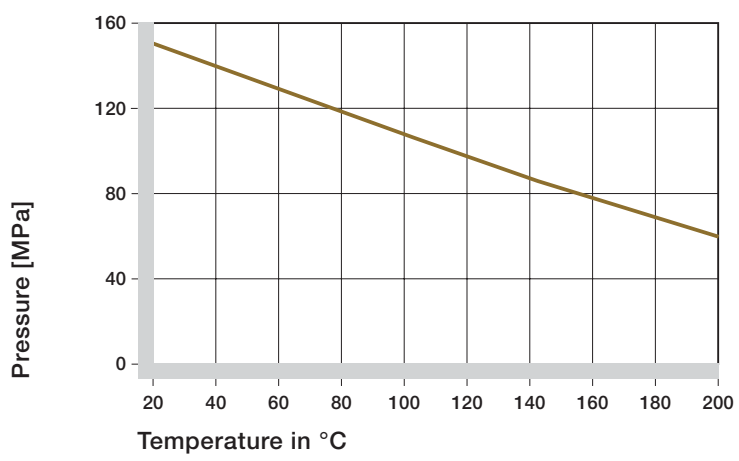

Graph 22.3: Recommended maximum surface pressure of iglidur® Z as a function of temperature

Diameter d1 [mm]	Shaft h9 [mm]	iglidur® Z F10 [mm]
up to 3	0 - 0,025	+0,006 + 0,046
> 3 to 6	0 - 0,030	+0,010 + 0,058
> 6 to 10	0 - 0,036	+0,013 + 0,071
> 10 to 18	0 - 0,043	+0,016 + 0,086
> 18 to 30	0 - 0,052	+0,020 + 0,104
> 30 to 50	0 - 0,062	+0,025 + 0,125
> 50 to 80	0 - 0,074	+0,030 + 0,150

Table 22.4: Essential tolerances for iglidur® Z plain bearings according to ISO 3547-1 after pressfit

Surface Pressure

Iglidur® Z is a high temperature bearing material, which is suited for applications with very high specific loads. For radial pressures between 50 and 100 MPa there is no better dry running wear resistant iglidur® material. Graph 22.2 shows the elastic deformation of iglidur® Z under exposure to radial loads. At the recommended maximum surface pressure of 150 MPa, the deformation is approximately 5.5% at room temperature.

- Graph 22.2
- Surface Pressure, page 1.18

Permissible Surface Speeds

iglidur® Z is suited for both average and high speeds due to its high thermal resistance. The maximum values given in table 22.2 can only be achieved at the lowest pressure loads. At the given speeds, friction can cause the temperature to increase to constant maximum permissible levels.

- Surface Speed, page 1.20
- p x v value, page 1.22

Temperatures

The maximum permissible short term temperature is 310°C. This is among the highest thermal resistance of any iglidur® material.

With increasing temperatures, the compressive strength of iglidur® Z plain bearings decreases. Graph 22.3 shows this relationship.

The ambient temperatures in the bearing system also have an effect on the bearing wear. With increasing temperatures, the wear rate increases.

Graph 22.4 shows that when the temperature increases from room temperature to 150°C, the wear rate of iglidur® Z only doubles. At high temperatures iglidur® Z is also the most wear resistant material when running dry.

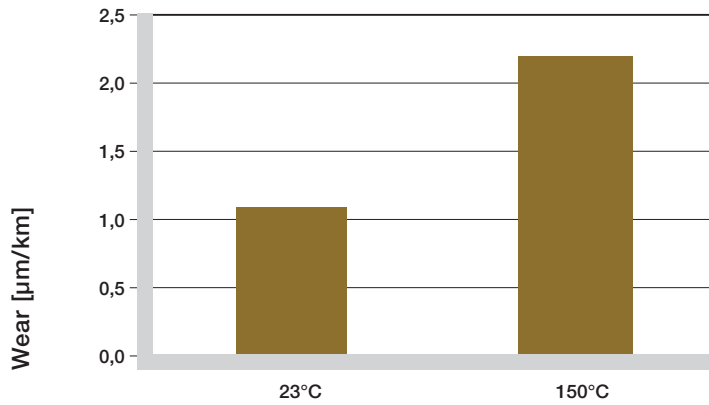

Graph 22.4: Wear of iglidur® Z, as a function of temperature, rotation with $p = 0.75 \text{ MPa}$, $v = 0.5 \text{ m/s}$ (CF53 hardened and ground steel)

iglidur®Z	Dry	Grease	Oil	Water
C.o.f. [μ]	0,06 - 0,14	0,09	0,04	0,04

Table 22.5: Coefficients of friction for iglidur® Z against steel ($R_a = 1 \text{ }\mu\text{m}$, 50 HRC)

Graphs 22.3 and 22.4

Application Temperatures, page 1.23

Friction and Wear

Similar to wear resistance, the coefficient of friction only changes slightly with increasing load. Friction and wear are also dependent, to a large degree, on the shaft material. Shafts that are too smooth increase both the coefficient of friction and the wear of the bearing. iglidur® Z proves to be relatively resistant in regard to the shaft surface. A ground surface with an average roughness 0.4 to 0.8 μm is best suited, when minimal friction is required.

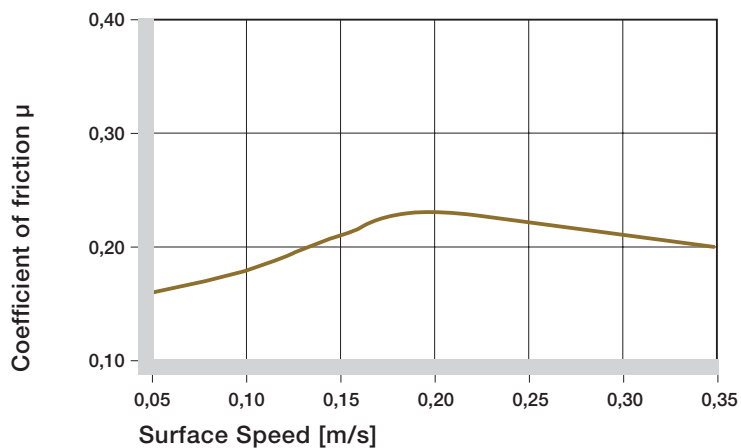

Graph 22.5: Coefficients of friction of iglidur® Z as a function of the running speed; $p = 0.75 \text{ MPa}$

Graphs 22.5 and 22.7

Coefficients of Friction and Surfaces, page 1.25

Wear Resistance, page 1.26

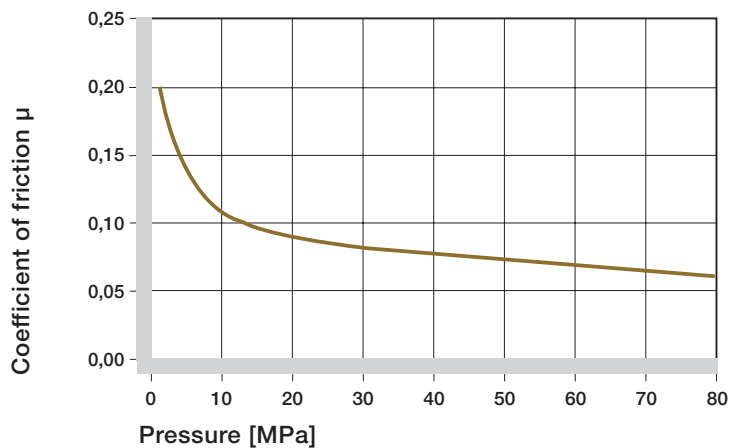

Graph 22.6: Coefficients of friction of iglidur® Z as a function of the pressure, $v = 0.01 \text{ m/s}$

iglidur® Z

Phone +49 - 22 03 - 96 49-145
Fax +49 - 22 03 - 96 49-334

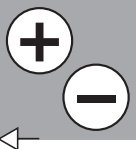



iglidur® Z

Phone +49 - 22 03 - 96 49-145
 Fax +49 - 22 03 - 96 49-334

iglus® GmbH
 51147 Cologne

Internet www.igus.de
 E-mail info@igus.de

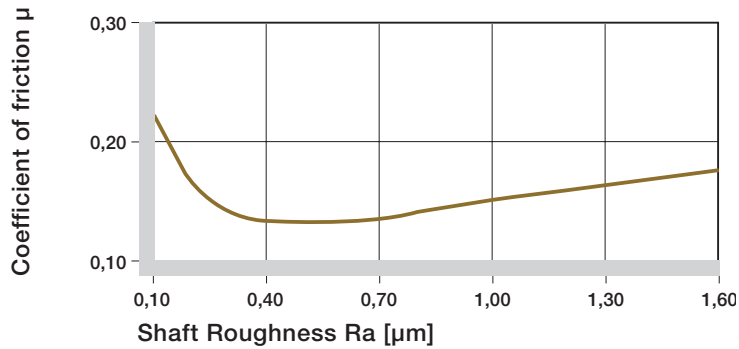

Graph 22.7: Coefficients of friction of iglidur® Z as a function of the shaft surface (Cf53 hardened and ground steel)

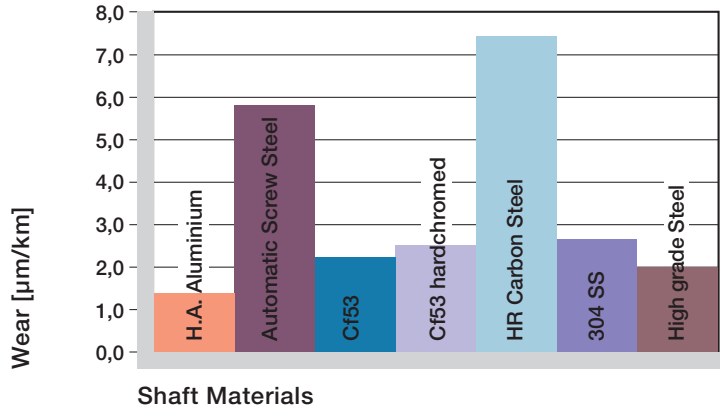

Graph 22.8: Wear of iglidur® Z, rotating applications with different shaft materials p = 0.75 MPa, v = 0.5m/s

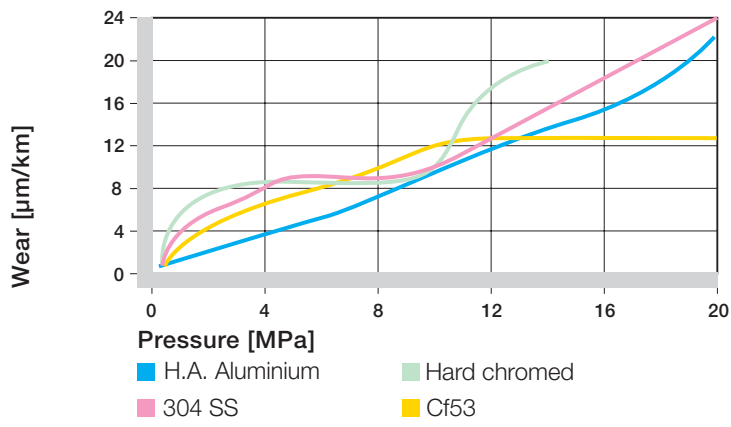

Graph 22.9: Wear of iglidur® Z with different shaft materials in rotating applications

Medium	Resistance
Alcohol	0
Hydrocarbons	+
Greases, oils without additives	+
Fuels	+
Diluted acids	+
Strong acids	-
Diluted alkalines	+
Strong alkalines	-

Table 22.6: Chemical resistance of iglidur® Z – detailed list, page 70.1

+ resistant 0 conditionally resistant - not resistant
 All data given at room temperature [20°C]

Shaft Materials

The graphs show wear rates in the lower load range, which are very similar to those of other iglidur® materials. However, in the upper load range iglidur® Z outperforms all other materials in wear resistance. Provided a Cf53 hardened and ground steel shaft is used, the wear is at 45 MPa still only 15 μm/km.

For low loads iglidur® Z plain bearings wear less in oscillating operation than in rotation. 303 Stainless Steel and hard chromed shaft are of interest here. The value 0.5 μm/km shows 303 Stainless provides the lowest wear in oscillating movements at 2 MPa. For higher loads, hard chromed shafts outperform 303 Stainless. However even at 100 MPa iglidur® Z gives excellent wear values. If the shaft material you plan to use is not contained in this list, please contact us.

☑ Graphs 22.8 to 22.11
 ▶ Shaft Materials, page 1.28

Installation Tolerances

iglidur® Z plain bearings are meant to be oversized before being pressfit. The bearings are designed for pressfit into a housing machined to a H7 tolerance. After being assembled into a nominal size housing, the inner diameter adjusts to meet our specified tolerances. Please adhere to the catalogue specifications for housing bore and recommended shaft sizes. This will help to ensure optimal performance of iglidur® Z plain bearings.

▶ Testing Methods, page 1.32/1.33

Chemical Resistance

iglidur® Z plain bearings have a very good resistance to chemicals. They have an excellent resistance against organic solvents, fuels, oils and greases. The material is only partially resistant against weak acids. The moisture absorption of iglidur® Z plain bearings is approximately 0.3% in standard atmosphere. The saturation limit in water is 1.1%.

☑ Graph 22.10
 ▶ Chemical Table, page 70.1

iglidur® Z | Technical data

Radiation Resistance

Plain bearings made from iglidur® Z are resistant to radiation up to an intensity of 1×10^5 Gy.

UV Resistance

UV radiation causes approximately 50% decline of the tribological properties (wear resistance) of plain bearings made from iglidur® Z.

Vacuum

For use in a vacuum environment, moisture content is released as vapour. Therefore, only dehumidified bearings made of iglidur® Z are suitable for a vacuum environment.

Electrical Properties

iglidur® Z plain bearings are electrically insulating.

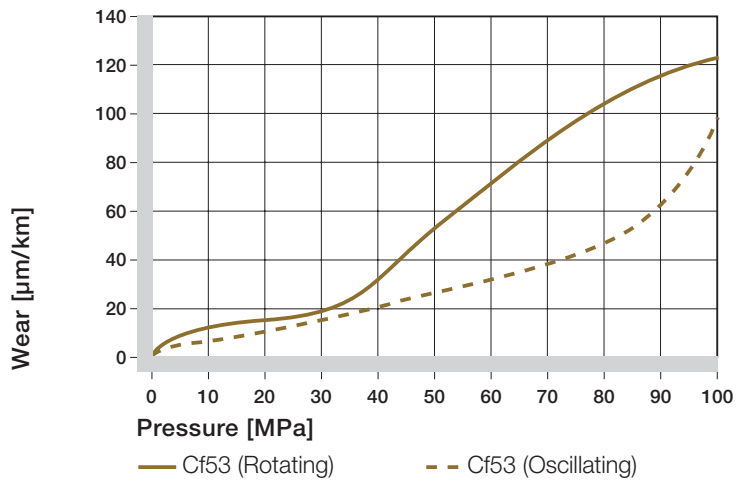

Graph 22.10: Wear for oscillating and rotating applications with Cf53 hardened and ground steel

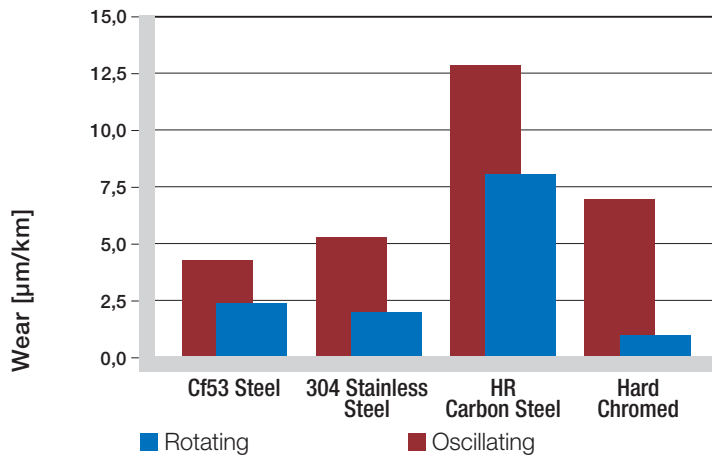

Graph 22.11: Wear for oscillating and rotating applications with different shaft materials, p = 2 MPa

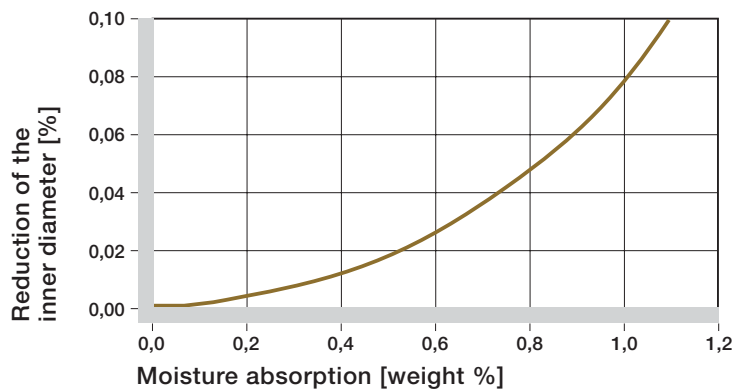

Graph 22.12: Effect of moisture absorption on iglidur® Z plain bearings

iglidur® Z

Specific	
Volume resistant	$> 10^{11} \Omega\text{cm}$
Surface resistant	$> 10^{11} \Omega$

Table 22.7: Electrical properties of iglidur® Z

iglidur® Z

Phone +49 - 22 03 - 96 49-145
Fax +49 - 22 03 - 96 49-334

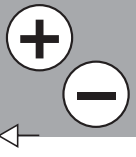



iglidur® Z | Sleeve Bearing | mm

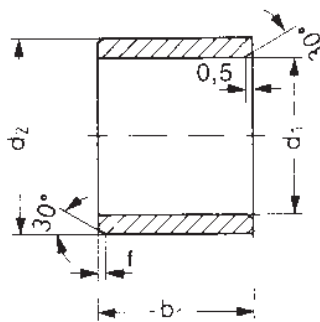

Data in mm

Structure – part no.
Z S M-0405-04



Chamfer in relation to the d1

d1 [mm]:	Ø 1-6	Ø 6-12	Ø 12-30	Ø > 30
f [mm]:	0,3	0,5	0,8	1,2

Dimensions according to ISO 3547-1 and special dimensions

Part Number	d1	d1-Tolerance*	d2	b1 h13	Part Number	d1	d1-Tolerance*	d2	b1 h13
ZSM-0405-04	4,0	+0,010 +0,058	5,5	4,0	ZSM-2023-20	20,0	+0,020 +0,104	23,0	20,0
ZSM-0507-05	5,0	+0,010 +0,058	7,0	5,0	ZSM-2023-30	20,0	+0,020 +0,104	23,0	30,0
ZSM-0608-08	6,0	+0,010 +0,058	8,0	8,0	ZSM-2023-35	20,0	+0,020 +0,104	23,0	35,0
ZSM-0608-12	6,0	+0,010 +0,058	8,0	12,0	ZSM-2225-20	22,0	+0,020 +0,104	25,0	20,0
ZSM-0810-08	8,0	+0,013 +0,071	10,0	8,0	ZSM-2528-20	25,0	+0,020 +0,104	28,0	20,0
ZSM-0810-10	8,0	+0,013 +0,071	10,0	10,0	ZSM-2528-30	25,0	+0,020 +0,104	28,0	30,0
ZSM-1012-08	10,0	+0,013 +0,071	12,0	8,0	ZSM-2528-48	25,0	+0,020 +0,104	28,0	48,0
ZSM-1012-10	10,0	+0,013 +0,071	12,0	10,0	ZSM-3034-30	30,0	+0,020 +0,104	34,0	30,0
ZSM-1012-12	10,0	+0,013 +0,071	12,0	12,0	ZSM-3034-40	30,0	+0,020 +0,104	34,0	40,0
ZSM-1214-15	12,0	+0,016 +0,086	14,0	15,0	ZSM-3539-20	35,0	+0,025 +0,125	39,0	20,0
ZSM-1517-15	15,0	+0,016 +0,086	17,0	15,0	ZSM-4044-40	40,0	+0,025 +0,125	44,0	40,0
ZSM-1618-12	16,0	+0,016 +0,086	18,0	12,0	ZSM-4044-47	40,0	+0,020 +0,104	44,0	47,0
ZSM-1618-15	16,0	+0,016 +0,086	18,0	15,0	ZSM-5055-60	50,0	+0,025 +0,125	55,0	60,0
ZSM-1820-20	18,0	+0,016 +0,086	20,0	20,0	ZSM-6065-60	60,0	+0,025 +0,125	65,0	60,0
ZSM-2023-15	20,0	+0,020 +0,104	23,0	15,0					

*after pressfit. Testing methods ► page 1.32/1.33



Here iglidur® Z bearings led to significant reduction of costs. This was achieved by eliminating the maintenance work completely during the season, as well as reducing the weight.

Lifetime calculation, CAD files and much more support ► www.igus.de/en/z

mm

iglidur® Z – Type S

Phone +49 - 22 03 - 96 49-145
Fax +49 - 22 03 - 96 49-334

igus® GmbH
51147 Cologne

Internet www.igus.de
E-mail info@igus.de

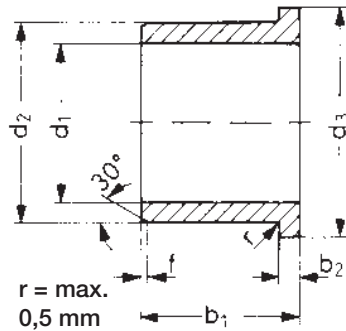

Data in mm

Structure – part no.

Z F M-0405-04



Chamfer in relation to the d1

d1 [mm]: Ø 1-6 | Ø 6-12 | Ø 12-30 | Ø > 30

f [mm]: 0,3 | 0,5 | 0,8 | 1,2

Dimensions according to ISO 3547-1 and special dimensions

Part Number	d1	d1-Tolerance*	d2	d3		b2
				d13	h13	
ZFM-0405-04	4,0	+0,010 +0,058	5,5	9,5	4,0	0,75
ZFM-0507-05	5,0	+0,010 +0,058	7,0	11,0	5,0	1,0
ZFM-0608-08	6,0	+0,010 +0,058	8,0	12,0	8,0	1,0
ZFM-0810-09	8,0	+0,013 +0,071	10,0	15,0	9,0	1,0
ZFM-1012-09	10,0	+0,013 +0,071	12,0	18,0	9,0	1,0
ZFM-1214-09	12,0	+0,016 +0,086	14,0	20,0	9,0	1,0
ZFM-1214-12	12,0	+0,016 +0,086	14,0	20,0	12,0	1,0
ZFM-1214-20	12,0	+0,016 +0,086	14,0	20,0	20,0	1,0
ZFM-1416-17	14,0	+0,016 +0,086	16,0	22,0	17,0	1,0
ZFM-1517-11	15,0	+0,016 +0,086	17,0	23,0	11,0	1,0
ZFM-1517-15	15,0	+0,016 +0,086	17,0	23,0	15,0	1,0
ZFM-1820-04	18,0	+0,013 +0,071	20,0	26,0	4,0	1,0
ZFM-1820-17	18,0	+0,013 +0,071	20,0	26,0	17,0	1,0
ZFM-2022-21	20,0	+0,013 +0,071	22,0	30,0	21,0	1,0
ZFM-2023-11	20,0	+0,020 +0,104	23,0	30,0	11,5	1,5
ZFM-2023-21	20,0	+0,020 +0,104	23,0	30,0	21,5	1,5
ZFM-2023-31	20,0	+0,020 +0,104	23,0	30,0	31,5	1,5
ZFM-2528-16	25,0	+0,020 +0,104	28,0	35,0	16,5	1,5
ZFM-2528-21	25,0	+0,020 +0,104	28,0	35,0	21,5	1,5
ZFM-2528-31	25,0	+0,020 +0,104	28,0	35,0	31,5	1,5
ZFM-3034-20	30,0	+0,020 +0,104	34,0	42,0	20,0	2,0
ZFM-3034-26	30,0	+0,020 +0,104	34,0	42,0	26,0	2,0
ZFM-3034-37	30,0	+0,020 +0,104	34,0	42,0	37,0	2,0
ZFM-3539-26	35,0	+0,025 +0,125	39,0	47,0	26,0	2,0
ZFM-4044-20	40,0	+0,025 +0,125	44,0	52,0	20,0	2,0
ZFM-4044-40	40,0	+0,025 +0,125	44,0	52,0	40,0	2,0
ZFM-6065-50	60,0	+0,030 +0,150	65,0	73,0	50,0	2,5
ZFM-7580-50	75,0	+0,030 +0,150	80,0	88,0	50,0	2,5

*after pressfit. Testing methods ► page 1.32/1.33

iglidur® Z – Type F

mm

Phone +49 - 22 03 - 96 49-145
Fax +49 - 22 03 - 96 49-334



iglidur® Z | Thrust Washer | mm

mm

iglidur® Z – Type T

Phone +49 - 22 03 - 96 49-145
Fax +49 - 22 03 - 96 49-334

igus® GmbH
51147 Cologne

Internet www.igus.de
E-mail info@igus.de

22.10

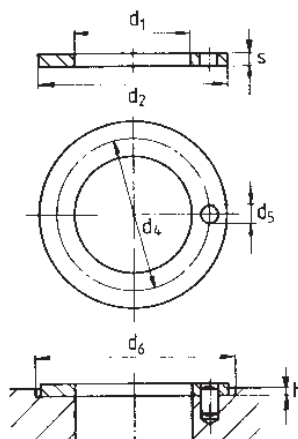

Data in mm

Structure – part no.
Z T M-1527-015



Dimensions according to ISO 3547-1
and special dimensions

Part Number	d1	d2	s	d4	d5	h	d6
	+0,25	-0,25	-0,05	-0,12 +0,12	+0,375 +0,125	+0,2 -0,2	+0,12
ZTM-1527-015	15,0	27,0	1,5	–	–	1,0	27,0
ZTM-1623-015	16,0	23,0	1,5	–	–	1,0	23,0
ZTM-2644-015	26,0	44,0	1,5	35,0	3,0	1,0	44,0
ZTM-3254-015	32,0	54,0	1,5	43,0	4,0	1,0	54,0
ZTM-4874-020	48,0	74,0	2,0	61,0	4,0	1,5	74,0
ZTM-6290-020	62,0	90,0	2,0	–	–	1,5	90,0

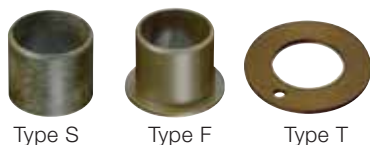

Order example

Our price breaks are defined by the order quantity.

1– 9	50– 99	500– 999
10–24	100–199	1000–2499
25–49	200–499	2500–4999

For the current prices please visit the igus®-Homepage
www.igus.de/en

No minimum order quantities, no surcharges.

Lifetime calculation, CAD files and much more support ► www.igus.de/en/z

iglidur® Z | Sleeve Bearing | inch

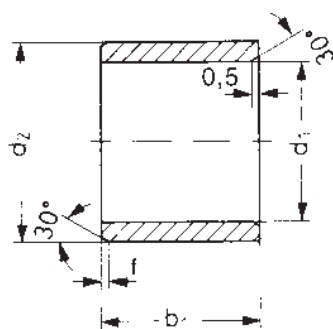

Data in inches

Structure - part no.
Z S I -0203-03



Chamfer in relation to the d1

d1 [mm]:	Ø 1-6	Ø 6-12	Ø 12-30	Ø > 30
f [mm]:	0,3	0,5	0,8	1,2

Part Number	d1	d2	b1	d1*		Housing Bore		Shaft Size	
				max.	min.	max.	min.	max.	min.
ZSI-0203-03	1/8	3/16	3/16	,1269	,1251	,1878	,1873	,1243	,1236
ZSI-0506-06	5/16	3/8	3/8	,3148	,3125	,3753	,3747	,3115	,3106
ZSI-0607-04	3/8	15/32	1/4	,3768	,3745	,4691	,4684	,3740	,3731
ZSI-0607-06	3/8	15/32	3/8	,3768	,3745	,4691	,4684	,3740	,3731
ZSI-0607-08	3/8	15/32	1/2	,3768	,3745	,4691	,4684	,3740	,3731
ZSI-0708-08	7/16	17/32	1/2	,4399	,4371	,5316	,5309	,4365	,4355
ZSI-0809-12	1/2	19/32	3/4	,5024	,4996	,5941	,5934	,4990	,4980
ZSI-0810-12	1/2	5/8	3/4	,5034	,5006	,6260	,6250	,5000	,4990
ZSI-1011-12	5/8	23/32	3/4	,6274	,6246	,7192	,7184	,6240	,6230
ZSI-1214-12	3/4	7/8	3/4	,7532	,7499	,8755	,8747	,7491	,7479
ZSI-1214-16	3/4	7/8	1	,7532	,7499	,8755	,8747	,7491	,7479
ZSI-1416-16	7/8	1	1	,8782	,8749	1,0005	,9997	,8741	,8729
ZSI-1618-16	1	1 1/8	1	1,0032	,9999	1,1255	1,1247	,9991	,9979
ZSI-1618-24	1	1 1/8	1 1/2	1,0032	,9999	1,1255	1,1247	,9991	,9979
ZSI-1820-24	1 1/8	1 9/32	1 1/2	1,1279	1,1246	1,2818	1,2808	1,1238	1,1226
ZSI-2022-20	1 1/4	1 13/32	1 1/4	1,2537	1,2498	1,4068	1,4058	1,2488	1,2472
ZSI-2426-24	1 1/2	1 21/32	1 1/2	1,5037	1,4998	1,6568	1,6558	1,4988	1,4972
ZSI-2831-32	1 3/4	1 15/16	2	1,7536	1,7497	1,9381	1,9371	1,7487	1,7471
ZSI-3235-16	2	2 3/16	1	2,0040	1,9993	2,1883	2,1871	1,9981	1,9969
ZSI-3235-32	2	2 3/16	2	2,0040	1,9993	2,1883	2,1871	1,9981	1,9969
ZSI-3639-32	2 1/4	2 7/16	2	2,2556	2,2519	2,4377	2,4365	2,2507	2,2489

*after pressfit. Testing methods ► page 1.32/1.33

iglidur® Z - Type S

inch

Phone +49 - 22 03 - 96 49-145
Fax +49 - 22 03 - 96 49-334

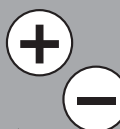



iglidur® Z | Flange Bearing | inch

inch

iglidur® Z – Type F

Phone +49 - 22 03 - 96 49-145
 Fax +49 - 22 03 - 96 49-334

igus® GmbH
 51147 Cologne

Internet www.igus.de
 E-mail info@igus.de

22.12

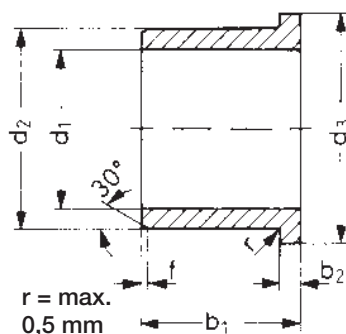

Data in inches

Structure – part no.
Z F I -0607-08



Chamfer in relation to the d1

d1 [mm]:	Ø 1-6	Ø 6-12	Ø 12-30	Ø > 30
f [mm]:	0,3	0,5	0,8	1,2

Part Number	d1	d2	b1	d3	b2	d1*		Housing Bore		Shaft Size	
						max.	min.	max.	min.	max.	min.
ZFI-0607-08	3/8	15/32	1/2	,687	,046	,3768	,3745	,4691	,4684	,3740	,3731
ZFI-0809-08	1/2	19/32	1/2	,875	,046	,5024	,4996	,5941	,5934	,4990	,4980
ZFI-1012-08	5/8	3/4	1/2	,937	,046	,6284	,6256	,7510	,7500	,6250	,6240
ZFI-1214-12	3/4	7/8	3/4	1,125	,062	,7532	,7499	,8755	,8747	,7491	,7479
ZFI-1214-16	3/4	7/8	1	1,125	,062	,7532	,7499	,8755	,8747	,7491	,7479
ZFI-1416-12	7/8	1	3/4	1,250	,062	,8782	,8749	1,0005	,9997	,8741	,8729
ZFI-1416-16	7/8	1	1	1,250	,062	,8782	,8749	1,0005	,9997	,8741	,8729
ZFI-1618-08	1	1 1/8	1/2	1,375	,062	1,0032	,9999	1,1255	1,1247	,9991	,9979
ZFI-1618-16	1	1 1/8	1	1,375	,062	1,0032	,9999	1,1255	1,1247	,9991	,9979
ZFI-1820-12	1 1/8	1 9/32	3/4	1,562	,078	1,1279	1,1246	1,2818	1,2808	1,1238	1,1226
ZFI-1820-24	1 1/8	1 9/32	1 1/2	1,562	,078	1,1279	1,1246	1,2818	1,2808	1,1238	1,1226
ZFI-2022-20	1 1/4	1 13/32	1 1/4	1,687	,078	1,2537	1,2498	1,4068	1,4058	1,2488	1,2472
ZFI-2022-24	1 1/4	1 13/32	1 1/2	1,687	,078	1,2537	1,2498	1,4068	1,4058	1,2488	1,2472
ZFI-2426-24	1 1/2	1 21/32	1 1/2	2,000	,078	1,5037	1,4998	1,6568	1,6558	1,4988	1,4972
ZFI-2831-32	1 3/4	1 15/16	2	2,375	,093	1,7536	1,7497	1,9381	1,9371	1,7487	1,7471
ZFI-3235-32	2	2 3/16	2	2,625	,093	2,0040	1,9993	2,1883	2,1871	1,9981	1,9969

*after pressfit. Testing methods ► page 1.32/1.33